



# 50E47-843

## Universal Hot Surface Ignition Control

### INSTALLATION INSTRUCTIONS

**FAILURE TO READ AND FOLLOW ALL INSTRUCTIONS CAREFULLY BEFORE INSTALLING OR OPERATING THIS CONTROL COULD CAUSE PERSONAL INJURY AND/OR PROPERTY DAMAGE.**

## DESCRIPTION

The 50E47-843 is a universal replacement Hot Surface Ignition (HSI) control designed for maximum compatibility with existing systems. It features:

- A card port and six program keys to select the Trial for Ignition Time, Retries, Prepurge and Igniter Warm Up timings.
- A Jumper to accommodate systems using Direct Sense (sensing through ignitor) or Indirect Sense (using a Flame Sensor).
- LED indicator for quick system and module diagnostics and troubleshooting.

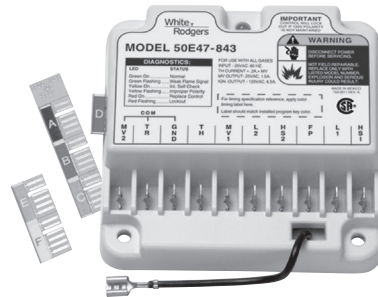

## PRECAUTIONS

### ⚠ GENERAL PRECAUTION

Application of this type of control may cause flame rollout on initial startup and could cause personal injury and/or property damage.

Check product specification and cross reference before replacing existing module. Do not use if existing module is not listed. Use of a program key other than listed can result in appliance malfunction.

If in doubt about whether your wiring is millivolt, line, or low voltage, have it inspected by a qualified heating and air conditioning contractor or licensed electrician.

Do not exceed the specification ratings.

All wiring must conform to local and national electrical codes and ordinances.

This control is a precision instrument, and should be handled carefully. Rough handling or distorting components could cause the control to malfunction.

### ⚠ CAUTION

To prevent electrical shock and/or equipment damage, disconnect electric power to system at main fuse or circuit breaker box until installation is complete.

Label all wires prior to disconnection when servicing controls. Wiring errors can cause improper and dangerous operation.

This control is not intended for use in locations where it may come in contact with water. Suitable protection must be provided to shield the control from exposure to water (dripping, spraying, rain, etc.).

### ⚠ WARNING

Do not use on circuits exceeding specified voltage. Higher voltage will damage control and could cause shock or fire hazard.

Do not short out terminals on gas valve or primary control to test. Short or incorrect wiring will damage thermostat and could cause personal injury and/or property damage.

### CONTENTS

Description .....	1
Precautions .....	1
Specifications .....	2
Installation .....	2
Mounting & Wiring .....	
Operation & Troubleshooting .....	4

# SPECIFICATIONS

## ELECTRICAL RATINGS:

**Input Voltage:** 18 to 30 VAC, 60 Hz

**Current:** 0.2 amp

## Relay Contact Ratings:

Valve Relay: 1.5 amp @ 25 VAC 60 Hz 0.6 PF  
 Ignitor Relay: 6.0 amp @ 120 VAC 60 Hz-resistive

## Flame Current Requirements:

Minimum current to insure flame detection: 2 µA DC\*  
 Maximum current for non-detection: 0.2 µA DC\*  
 Maximum allowable leakage resistance: 100 M ohms

\* Measured with a DC microammeter in series with the flame probe lead

## OPERATING TEMPERATURE RANGE:

-40° to 175°F (-40° to 80°C)

## HUMIDITY RANGE:

To 95% relative humidity (non-condensing)

## MOUNTING:

Surface mount or 4" x 4" junction box

**GASES APPROVED:** Natural, Manufactured, Mixed, Liquid Petroleum, and LP Gas Air Mixtures.

## Program Key Timing Specifications Quick Reference

Timing and Retry				
Program Key (Color)	Trial for Ignition	Retries	Prepurge	Interpurge Ignitor (Warmup)
A (blue)	4 Sec.	0	30 Sec.	45 Sec.
B (red)	4 Sec.	2	30 Sec.	45 Sec.
C (green)	7 Sec.	0	30 Sec.	45 Sec.
D (violet)	7 Sec.	2	30 Sec.	45 Sec.
E (orange)	4 Sec.	2	30 Sec.	17 Sec.
F (yellow)	7 Sec.	2	30 Sec.	17 Sec.

**NOTE:** Program keys are lettered and color coded.

# INSTALLATION

## MOUNTING AND WIRING

### WARNING

**Do not use on circuits exceeding specified voltage. Higher voltage will damage control and could cause shock or fire hazard.**

### CAUTION

**To prevent electrical shock and/or equipment damage, disconnect electric power to system at main fuse or circuit breaker box until installation is complete. Failure to earth ground the appliance or reversing the neutral and hot wire connection to the line can cause shock hazard.**

**Shut off main gas to heating system until installation is complete.**

**Route and secure all wiring as far from flame as practical to prevent fire and/or equipment damage.**

## NOTE

Replace control as unit –no user serviceable parts.

All wiring should be installed according to local and national electrical codes and ordinances.

The control may be mounted in any orientation on a convenient surface using two #6 x 5/8" sheet metal screws. If desired, control can be mounted on a 4" x 4" junction box using two #8-32 x 5/8" machine screws. The control must be secured to an area that will experience a minimum of vibration and remain below the maximum ambient temperature rating of 175°F. The control is approved for minimum ambient temperatures of -40°F.

Refer to the wiring diagrams and wiring table when connecting the control to other components of the system.

UL approved 105°C rated 18 gauge minimum wire is recommended for all low voltage connections. UL approved 105°C rated 16 gauge minimum wire is recommended for all line voltage connections. Refer to table below for recommended terminals to mate with those on the control.

After installation or replacement, follow appliance manufacturer's recommended installation/service instructions to insure proper operation.

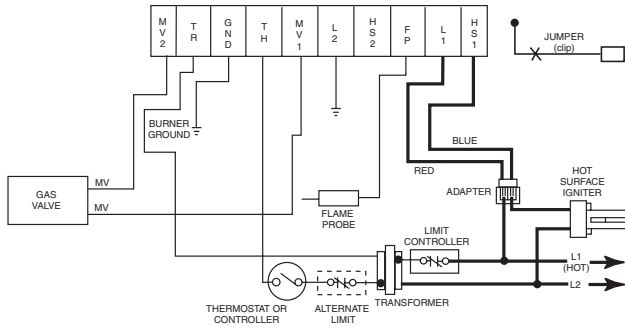

**Fig. 1 – Typical hookup for White-Rodgers replacement with indirect sense using flame probe**

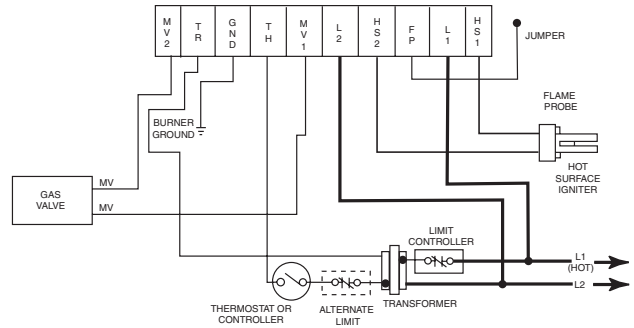

**Fig. 2 – Typical hookup for competitive replacement with direct flame sense through ignitor**

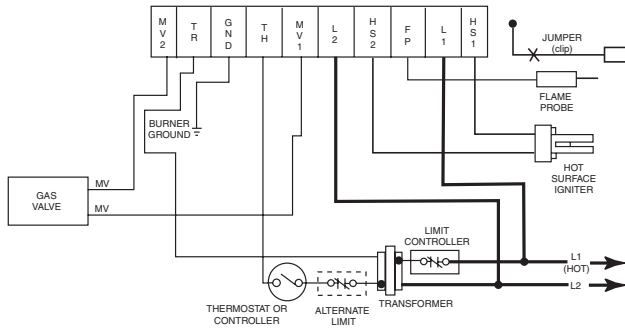

**Fig. 3 – Typical hookup for competitive replacement with indirect sense using flame probe**

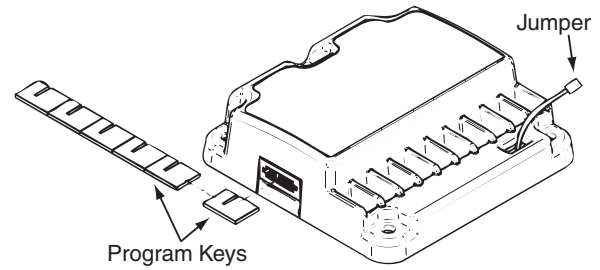

**Fig. 4 – Program Key installation/Jumper for models with indirect sense clip jumper**

## Terminal Wiring Cross Reference

Terminal Function	Original Control			Replacement Control
	Honeywell S89/S890 Terminal	Robertshaw HS780 Terminal	Old White-Rodgers 50E/F47 Terminal	50E47-843
Burner Ground Connection	GND (BURNER) <sup>a</sup>	TR (GND CLIP) <sup>b</sup>	GND	GND
Transformer Secondary (unswitched leg)	24V (GND) <sup>a</sup>	GND	TR	TR
Main Valve Common	VALVE (GND) <sup>a</sup>	— <sup>c</sup>	MV <sup>a</sup> (next to TR terminal)	MV2
Transformer Secondary (switched leg)	24V <sup>a</sup>	TH	TH	TH
Main Valve Operator	VALVE	VALVE <sup>d</sup>	MV <sup>d</sup>	MV1
120 Vac Neutral Leg	L2 120V NEUTRAL	L2	—	L2 <sup>e</sup>
Power Supply				
120 Vac Hot Leg	L1 120V HOT	L1	L <sup>f</sup>	L1 120V HOT
Power Supply				
Hot Surface Igniter Element	HSI 120V	IGN	—	HS2
Hot Surface Igniter Element	HSI 120V	IGN	IGN <sup>g</sup>	HSI
Flame Sensor	SEN <sup>h</sup>	RS <sup>h</sup>	FP <sup>i</sup>	FP <sup>h</sup>

<sup>a</sup> Remove quick-connect and replace with the included 1/4" quick-connect.

<sup>b</sup> Use green adapter cable (provided) to connect terminal to chassis ground.

<sup>c</sup> Do not use the MV2 terminal. MV2 and TR are interconnected in the appliance wiring.

<sup>d</sup> Remove quick-connect and replace with the included 3/16" quick-connect.

<sup>e</sup> Ground this terminal using green adapter cable if model being replaced does not have 120V neutral power supply connection.

<sup>f</sup> Use the red wire on the included adapter cable.

<sup>g</sup> Use the blue wire on the included adapter cable.

<sup>h</sup> On indirect sense models, remove jumper quick-connect from FP terminal, cut jumper wire at circuit board and discard.

On direct sense models, jumper connected to FP terminal, see figure 4.

<sup>i</sup> Remove jumper from FP terminal, cut jumper wire at circuit board and discard.

# INSTALLATION

## INSTALL PROGRAM KEY

The control replaces all listed models with the following features:

- 120 volt hot surface ignitor
- remote rod flame sense or direct flame sense through ignitor
- one or three ignition tries
- Seven or four second trial for ignition intervals
- Pre-purge of 30 seconds or less
- 60 second inter-purge time
- 17 or 45 second ignitor warm-up times

Six program keys are provided for different applications. Timings and Retries for each program key are shown in the Specifications section of this installation manual. Choose the

proper program key for the application by using the Module Cross Reference (37-7209). Install the selected program key in the slot on the left side of the module (see figure 4 on page 3).

If the module you are replacing is not listed in the Cross Reference, contact the manufacturer of the appliance for a recommended replacement or retrofit.

After inserting the proper program key, dispose of the remaining keys to ensure the correct key remains in the module.

Reversal of gas valve leads or open connection to MV1 and MV2 may cause control to lockout. See troubleshooting guide for remedy.

# OPERATION

## TYPICAL FURNACE INSTALLATION

In a typical application the 50E47-843 is designed to energize the ignitor and gas valve and monitor the flame sensor. It is a 100% shut off design that locks out the gas valve if the burner does not light within the trial for ignition period. The ignition sequence begins with a call for heat from the room thermostat. The thermostat applies power to the control. After pre-purge interval, the ignitor warms up for the selected time. The control energizes the gas valve for the selected

trial for ignition period. If the burner lights within the allowed period the gas valve will remain open until the call for heat is satisfied. During the trial for ignition period the ignitor is turned off. If the burner does not light, the control will either go into lockout or make two more ignition retries depending on the options selected. The control can be reset from lockout by cycling the thermostat to remove power for a minimum of 3 seconds. It includes a system analysis/troubleshooting LED that indicates normal operation, lockout, weak flame signal or internal control fault.

# TROUBLESHOOTING

For proper control operation, the control must be electrically connected to the gas valve and all the ignitor wiring connectors plugged in. Gas valves with an electric "ON/OFF" switch must have the switch set to "ON".

The light on the control provides a self-diagnosis indication. If the red light on the module is on continuously, the fault is likely to be internal to the module. To make sure, interrupt the line or 24 volt thermostat power for a few seconds and then restore. If the internal fault is indicated again, and flame sensor is not shorted to ground, replace the control. A flash-

ing light indicates the problem is most likely in the external components or wiring (see chart below). Proceed as follows:

Three visual checks

1. The ignitor will warm up and glow red
2. The main burner flame will ignite
3. The main burner flame will continue to burn after the ignitor is turned off

Troubleshooting the system consists of checking for these three visual indications. The chart on the next page defines the proper action if any of these indications do not occur.

LED	Condition
Green Solid On	Normal
Green Rapid Flashing	Weak flame signal
Red Rapid Flash	Control in lockout Flame sensed when there should be none
Red 1 Flash	Control in lockout Ignition retries exceeded
Red 2 Flash	Control in lockout Ignition recycles exceeded
Yellow Solid On	Internal self check
Yellow Rapid Flashing	Improper Polarity
OFF	Internal Failure
Red Solid On	Gas valve miswired or Internal error detected

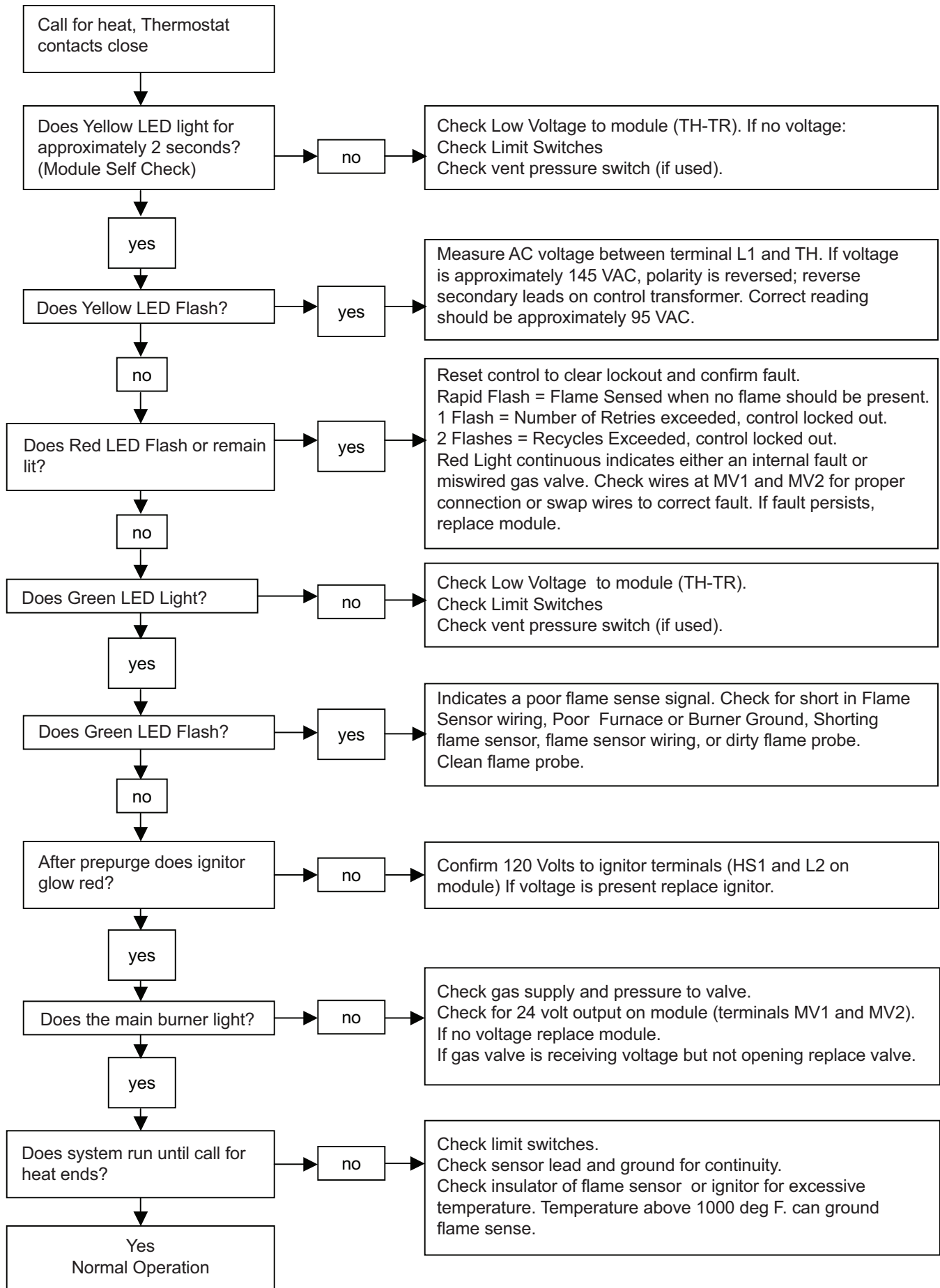

White-Rodgers is a division  
of Emerson Electric Co.

The Emerson logo is a  
trademark and service mark  
of Emerson Electric Co.

White   
Rodgers™

[www.white-rodgers.com](http://www.white-rodgers.com)  
[www.emersonclimate.com](http://www.emersonclimate.com)

  
**EMERSON™**  
Climate Technologies